

Optional Bracket

Brackets installation are according to door swing direction and door frame type , e. g. narrow frame door , frameless glass door , inswing door , etc.

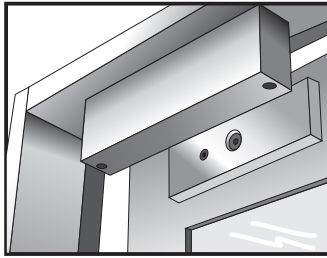

Regular Installation (outswing door)

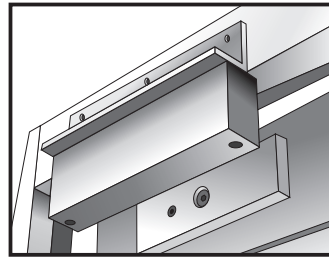

With L-bracket for narrow frames (optional)

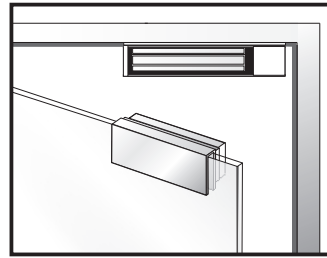

With U-bracket for frameless glass door (optional)

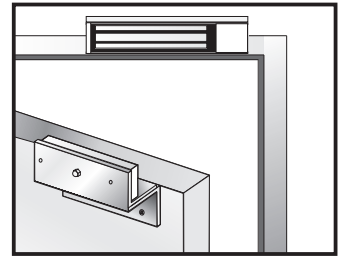

With LZ-bracket for inswing door (optional)

Regular Installation

1 Fold the mounting template as a 90° angle.
Template

2 Place the template to the proper position of the door and frame. Mark the hole position of template to the door frame.

3 Drill the holes according to the mark.

4 **Armature Plate**
 Please install the armature plate as the diagram. (Different dimension of the drilling holes are according to the door type as below instruction)

<p>Hollow Metal Door</p> <p>12.7mm 8mm</p>	<p>Reinforced Door</p> <p>6.8mm for M8-1.25 thread</p>	<p>Solid Door</p> <p>12.7mm 8mm 36mm</p>
<p>Drill a Ø8mm hole through door, from sexnut bolt side, enlarge to Ø12.7mm.</p>	<p>Drill a Ø6.8mm hole and tap for M8x12.5 thread.</p>	<p>Drill a Ø8mm hole through door from sexnut bolt side enlarge to Ø 12.7mm, 36mm in depth.</p>

Recommendation:
 Micro EM-locks (300 LBS) maximum thickness of door is 44 mm.
 Mini EM-locks (600 LBS) maximum thickness of door is 50 mm.
 Midi EM-locks (800 LBS) maximum thickness of door is 48 mm.
 Maxi EM-locks (1200 LBS) maximum thickness of door is 46 mm.

5 The rubber washer make the armature plate adjustable in order to reach the proper combination with magnet lock.
Rubber Washer

6 Insert the mounting screws. The mounting plate can be adjusted.

7 Fix the mounting plate on the door with mounting screws
Cable

8 Use the Allen wrench and fixing bolt to tighten the electromagnet lock to mounting plate.
Allen wrench

9 Connect the power and test the unit.
Power
Outswing

With LZ bracket for Inswing doors

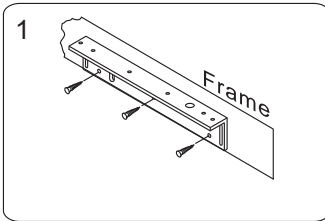

1 Find a mounting location on the door frame for the L bracket. Make sure that the door is still closeable.

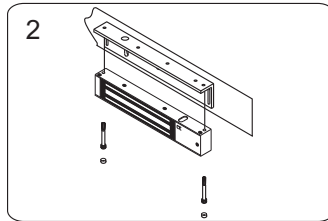

2 Use the fixing bolt to tighten the electromagnet lock on L bracket.

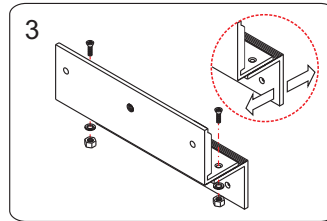

3 Assemble the Z bracket, and make sure that the Z bracket is adjustable.

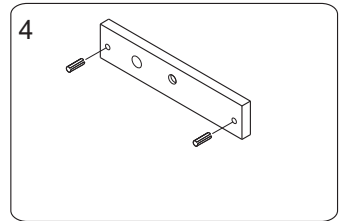

4 Insert the guide pins into the armature plate.

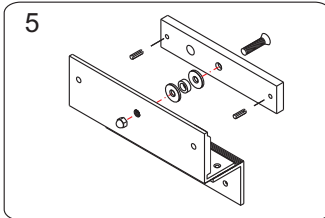

5 Assemble the armature plate (Rubber washer must be added)

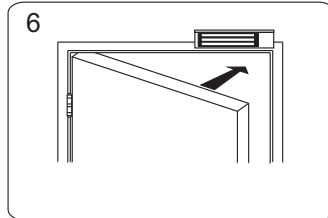

6 Close the door and connect the power.

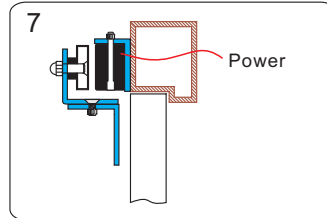

7 Adjust the position between Z bracket and the door frame. Then fix the Z bracket.

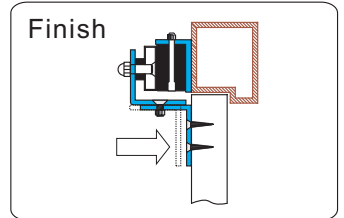

Finish Connect the power and test the unit.

Connecting Diagram

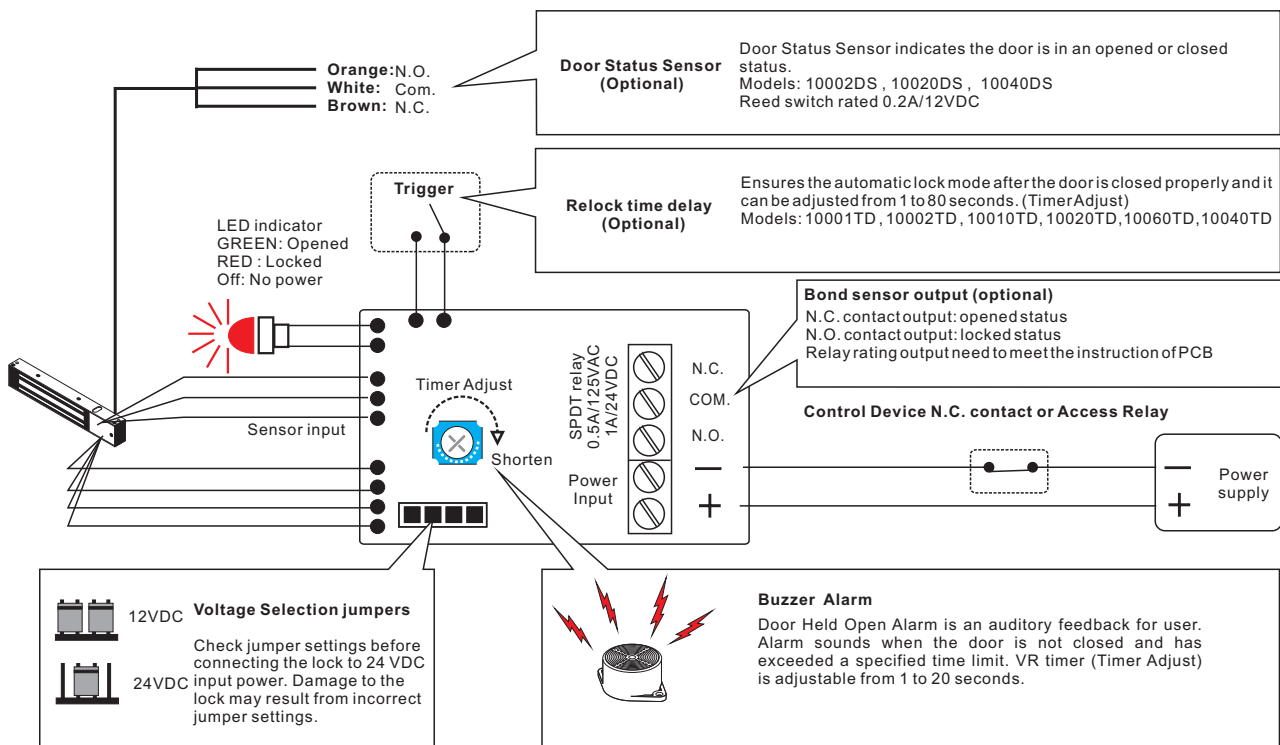

Trouble Shooting

Problem	Possible Cause	Solution
Door does not lock	No power	Make sure the wires are connected properly Check that the power supply is connected and working properly Make sure the lock switch is wired correctly
Low holding force	Poor contact between electromagnet and armature plate	Make sure if the armature plate is deformed? Make sure if the rubber washer was used between magnet lock and armature plate Make sure the contact surfaces of the electromagnet and armature plate are clean and free from dust
	Low voltage or incorrect voltage setting	Ensure the electromagnet lock is set for the correct voltage. Check for proper voltage at the electromagnetic locks input. If low, determine if the correct wire gauge is being used to prevent excessive voltage drop.
Sensor output is not functioning	A secondary diode was installed across the electromagnet lock	Remove any diode installed across the magnet for "spike" suppression. (The magnet is fitted with a metal oxide varistor to prevent back EMF)
	Misalignment between the reed switch and electromagnet lock	Make sure the armature plate and electromagnet lock are aligned correctly